



Temperature and humidity regulator



STR-102, STR-103, STR-104, STR-104S Instruction Manual

Ampèrestraat 35-37
NL-1446 TR PURMEREND

Postbus 783
NL-1440 AT PURMEREND

T (+31) 0299 630 610

F (+31) 0299 630 611

E info@atal.nl

I www.atal.nl

Table of content

1. GENERAL SAFETY RULES	3
2. GENERAL DESCRIPTION.....	4
3. REGULATOR MOUNTING AND CONNECTION	4
4. DESCRIPTION OF DEVICE FUNCTION AND SETTING	5
4.1. Relay outputs	5
4.2. Actual regulator preset	5
4.2.1. Value assigned to output relay.....	6
4.2.2. When close output relay.....	6
4.2.3. Delay.....	6
4.2.4. Hysteresis.....	7
4.3. Regulator setting change	7
4.3.1. Setting with PC and TSensor software.....	7
4.3.2. Setting with using regulator keys.....	8
4.3.3. Extended setting mode	8
4.4. Restore to „Factory default“ – measurement part	13
5. DEVICE CONNECTION	13
6. DIMENSIONS	14
7. ERROR STATES OF THE DEVICE.....	17
8. READINGS ON LCD DISPLAY	18
9. TECHNICAL SPECIFICATION	18
9.1. Technical parameters.....	18
9.1.1. Common parameters.....	18
9.1.2. STR-102 - temperature and humidity regulator.....	18
9.1.3. STR-104(S) - temperature and humidity regulator.....	19
9.1.4. STR-103 - temperature and humidity regulator.....	19
9.1.5. Relative humidity and temperature restriction	20
9.1.6. Value computed from measured relative humidity and temperature.....	20
9.2. Operating conditions	21
9.3. End of operation	22
9.4. Technical support and service	22
10. APPENDIX A	22
11. APPENDIX B	23

1. General safety rules

The following summary is designed to prevent injury hazards or device damage. Operate the instrument in accordance with this manual to prevent electric trauma.

Service should be performed by a qualified person only.

Use a safety ac/dc adapter. Use only an adapter with the power voltage recommended by its manufacturer and which is approved by proper standards. Check that the adapter has undamaged cables and cover.

Connect and disconnect correctly. Do not connect and disconnect a LAN cable or lead-in cables if the device is under electric voltage.

Do not use the instrument without the cover.

Do not use the instrument, if it does not work correctly. If the instrument seems not to work correctly, have it checked by a qualified service person.

Do not use the instrument in an explosive environment.

Read instruction manual before the first device connection, please.

Copyright: Atal B.V. It is prohibited to copy and edit this instruction manual and make any changes at all without explicit agreement of Atal B.V. All rights reserved.

Atal B.V. makes constant development and improvement of all its products. That is why it reserves the right to make any technical changes on the device/product without previous notice.

2. General description

Regulators of STR-10x line are designed for online monitoring of temperature in °C or °F and relative humidity of air without aggressive ingredients. Measured temperature and relative humidity are recomputed to following humidity expression: dew point temperature, absolute humidity, specific humidity, mixing ratio and specific enthalpy. The device is equipped with two relay outputs for alarming or controlling of external devices. It is possible to assign any input value to each relay, to set comparing limit, delay, hysteresis and acoustic alarm.

Type	Temperature	Humidity	Computed value	Version
STR-102	✓	✓	✓	Outdoor, indoor use.
STR-104	✓	✓	✓	Probe with cable
STR-104S	✓	✓	✓	Probe for compressed air *)
STR-103	✓	✓	✓	Duct mount

*) The removable probe for compressed air measurement is non interchangeable part of the device. The protection of connector is IP67

Device setting from the manufacturer

If special setting was not required in the order device is set from the manufacturer to the following parameters:

Value assigned to relay 1 and relay 2:	none
Password for setting through keys (PASS):	0000
LCD display:	on
value shown at first LCD line:	temperature
value shown at second LCD line:	relative humidity / dew point temperature
temperature unit:	°C
computed value preset:	dew point temperature
relay response for error:	stay unchanged at previous condition
acoustic alarm:	off

3. Regulator mounting and connection

Regulators are designed for wall mounting. Device must be mounted on the plane surface to prevent its deformation. Mounting holes and connection terminals are accessible after demounting of four screws in the corners of the box and removing the lid. There is recommended to use screws with half round head with cross-recessed screw ST 3.9 (DIN 7981). Lace the lead-in cable with outer diameter of 3 to 6.5 mm through the glands at the case wall and connect them according schematic below. Terminals are self-clamping and can be opened by a suitable screwdriver. For the opening, insert the screwdriver to smaller terminal hole and lever by him. Do not forget to tighten glands and case lid with inserted packing after cables connecting. Insert attached plug into unused cable glands too. Do NOT connect the regulator under voltage.

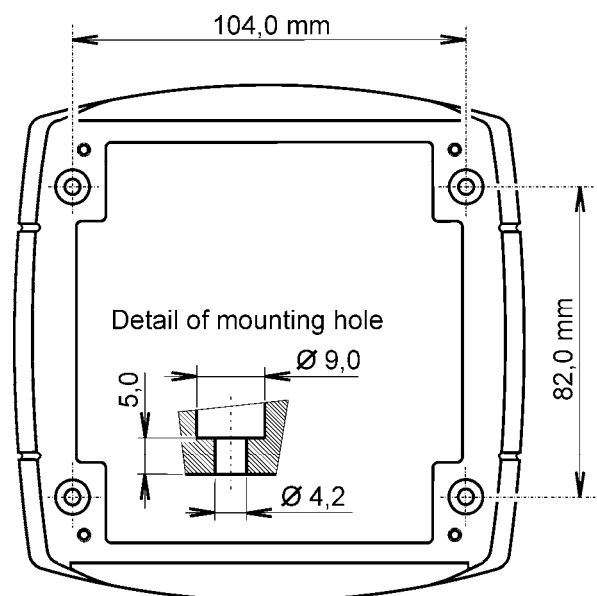

It is NOT recommended to use the device for long time under condensation conditions. It could be the cause of water steam condensation inside the sensor's cover into water phase. This liquid phase stays inside sensor's cover and can't escape from the cover easily. It can dramatically increase response time to relative humidity change. If water condensation occurs for longer time it can cause sensor damage. Similar effect can occur under water aerosol conditions.

Electrical system (wiring) may be done only by a worker with required qualification by rules in operation.

Before you remove probe of the transmitter STR-xxxS, make sure that the pressure in a pressure chamber (duct, pipe ...) and the ambient pressure are in equilibrium.

4. Description of device function and setting

4.1. Relay outputs

Regulator is equipped with two relay outputs. It is possible to assign any input or computed value to each relay, to set comparing alarm limit, if the relay may close if measured value is higher (Hi) or lower (Lo) than preset limit, delay for while must be preset condition true before relay close its contact and hysteresis for return to open status. Each relay status is indicated with LED diode and shown on LCD with corresponding symbols „ALARM 1“ or „ALARM 2“.

The output relays of device are not able to switch power circuits or higher voltages. In such case we should use suitable type of power relays with coil in accordance to chapter “Common parameters”. For wiring see Appendix A.

4.2. Actual regulator preset

- It is possible to display actual regulator preset on its LCD display by pressing of „▲“ key. LCD shows information about relay 1 and then relay 2 setting step by step. Information about relay 1 are indicated with symbol „ALARM 1“, for relay 2 with symbol „ALARM 2“ (at right top corner of LCD). It is possible to edit parameters after pressing „SET“ key and entering of correct password „PASS“ – see chapter 4.3.2 at page 8. Following examples are for relay 1 setting, similarly are displayed values for relay 2. Pressing of „ESC“ key ends this mode and switch to actual value displaying, the same occur if more than 20 s is not pressed any key.

4.2.1. Value assigned to output relay

None, relay is still off

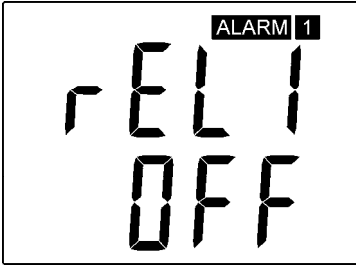

Temperature at °C

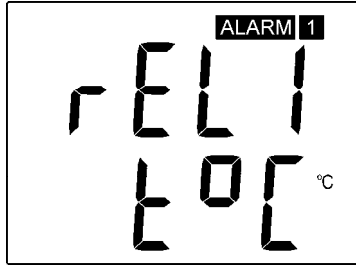

Relative humidity

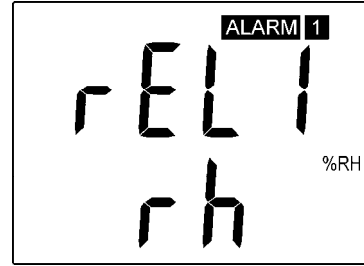

Computed value – dew point temperature



4.2.2. When close output relay

Preset if relay is closed when actual value is higher „HI“ or lower „Lo“ than preset value.

Value higher than 26.5 °C

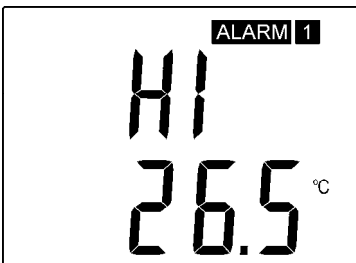

Value lower than 26.5 °C

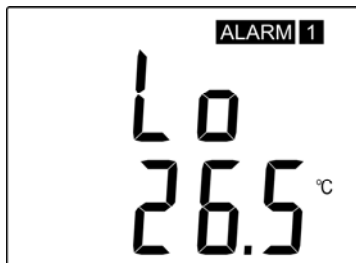

4.2.3. Delay

Time in seconds, when preset condition must be true and after this time output relay is closed (transient reduction of measured value)

Delay in [s]

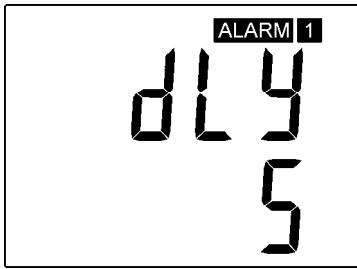

4.2.4. Hysteresis

The amount of measured value which must go under/over preset value to open appropriate output relay. It means if there is condition: relay 1 must be closed if measure value is “higher then” (HI), then measured value must decrease by this value under preset limit to relay output goes open. If condition of relay is: relay 1 must be closed if measured value is “lower than” (Lo), then measured value must be increased by this value over preset limit to relay output goes open.

Preset hysteresis value

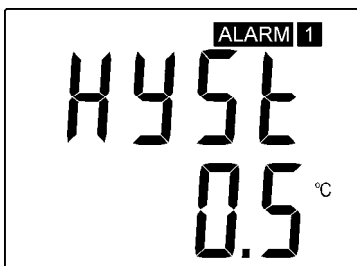

4.3. Regulator setting change

4.3.1. Setting with PC and TSensor software

Device adjustment is performed by means of optional **ATS-AC02** communication cable, connected to USB port of PC. For setting all parameters of regulator it is necessary to have installed program **TSensor** on the PC. It is free to download at www.atal.nl . Follow the program instructions. Regulator includes hardware write protection of internal setting, new setting is possible to write only while:

1. during write period press „SET“ key – do requested setting in TSensor software, press „SET“ key on regulator and keep it down, then click on the button „Save Changes“ into TSensor software and after end of write release „SET“ key, or
2. jumper placed nearby keys is closed (jumper is accessible after demounting of four screws in the corners of the box and removing the lid, don't confuse with jumper nearby Ethernet connector!). This jumper is suitable e.g. until device adjustment is in process and regulator is placed into calibration box and keys are not accessible. Don't forget to remove (open) jumper after procedure finish (restore write protection)

4.3.2. Setting with using regulator keys

If „Actual regulator preset” is displayed, it is possible to enter into edit mode and edit displayed value by pressing „SET” key. You can edit selected value if right password is entered. During value editing there is range check executed and edited value is still compared with limits for corresponding value (range). If inserted value is higher or lower then edited number is automatically changed to its maximum / minimum value – for possible range see chapter „Technical parameters“ at page 18. Value can be changed with using „▲” and „▼” keys. Edited value is switched in “round” -9, -8, -7, ...-2, -1, 0, 1, 2, ...8, 9. To edit next number digit press „SET” key, for moving back to previous digit press „ESC” key. Edited value is stored by next „SET” key pressing. It is possible to cancel editing by pressing „ESC” key if necessary. If valid password is once inserted right, then there is possible to edit next items without asking for password insertion again, till “Actual regulator preset” is left (till actual measured values are shown). With new entering into edit mode it is necessary to enter Password again. Default password setting is preset from manufacturer to 0000, password change is possible into „Extended setting”. During edit mode regulator still works and changes are valid immediately after its storing – it is NOT necessary to restart regulator.

4.3.3. Extended setting mode

During regulator operation it is possible to change only parameters described in chapter “Actual regulator preset” at page 5. Rest of regulator parameters are available through “Extended setting mode”. **In this mode regulator does NOT communicate, does NOT do any measurements and does NOT service output relays. To leave this mode press „ESC” key and open jumper nearby keys.**

To enter into Extended setting mode do following steps:

1. disconnect power supply
2. demount four screws in the corners of the box and remove the lid
3. closed jumper placed nearby keys (don't confuse with jumper nearby Ethernet connector)
4. press „▲” and „▼” keys together and keep them down
5. connect power supply to regulator – you should see message „SEL” on the top line of LCD and on the bottom line you should see number of Firmware version (e.g. 0400)
6. release „▲” and „▼” keys – you are into “Extended setting mode” now

Use „▲” and „▼” keys to inspect each items. If you want to change some shown item then press „SET” key, item starts blink. Now you can edit setting with using „▲” and „▼” keys. To store preset value press „SET” key. Press „ESC” key to leave editing (changing) without save – last stored value is kept.

Into this mode you can set following items:

Acoustic alarm assign to relay 1

acoustic indication of relay 1 is OFF

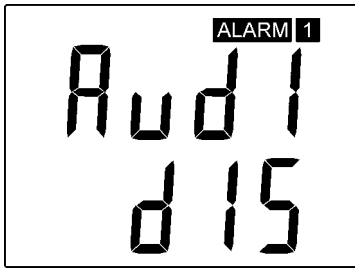

close of relay 1 contact starts acoustic indication

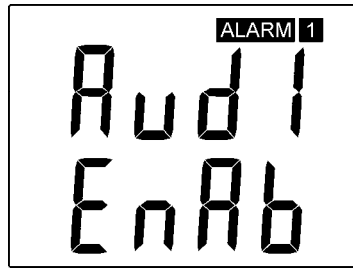

Acoustic alarm assign to relay 2

acoustic indication of relay 2 is OFF

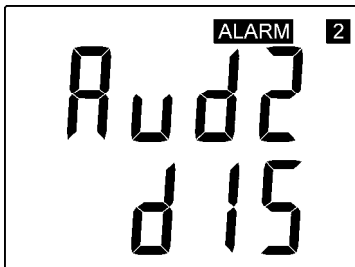

close of relay 2 contact starts acoustic indication

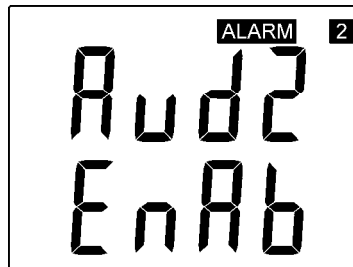

Acoustic alarm deactivation

activated acoustic alarm is possible to deactivate by pressing „ESC“ key



acoustic alarm is still activated for all time and it is impossible to deactivate it



Relay response for error

- Regulator continuously checks its state during operation (see chapter “

Error States of the device“ at page 17. In case error of assigned value measurement is found then output relay:

•
stays unchanged (in previous status)



Relay 1 switch OFF

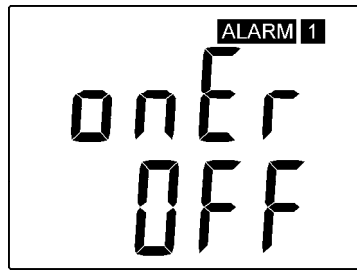

Relay 1 switch On



stays unchanged (in previous status)



Relay 2 switch OFF



Relay 2 switch On



Change of “Password for setting through keys” (PASS)

• This item shows actual password setting. It is possible to change it after „SET“ key pressing. It is number from range -19999 to +19999.

password setting

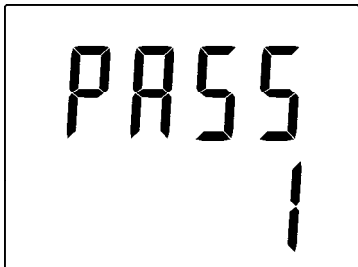

Temperature unit choice

It is possible to measure temperature at °C or °F. There is shown preset unit. It is possible to change it after „SET“ key pressing.

preset to °C

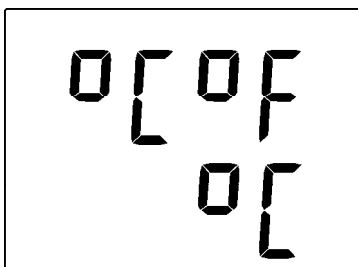

preset to °F

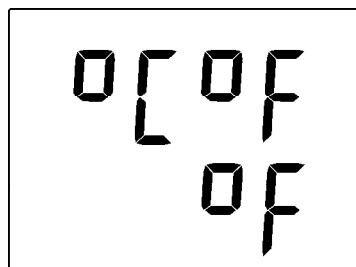

Show temperature at LCD display

This item provides to choice if actual measured temperature may be displayed at LCD display or not. It is possible to change it after „SET“ key pressing.

show value on LCD

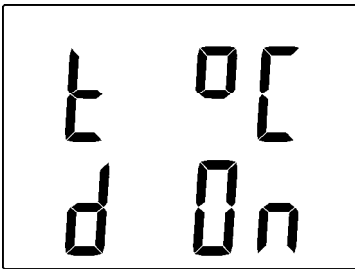

don't show value on LCD

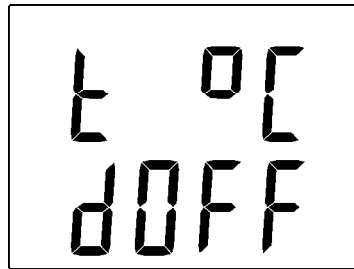

Show relative humidity at LCD display

This item provides to choice if actual measured relative humidity may be displayed at LCD display or not. It is possible to change it after „SET“ key pressing.

show value on LCD

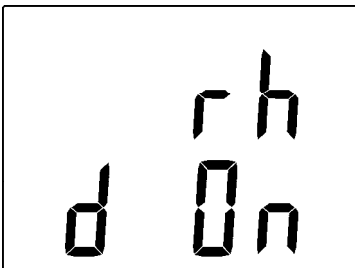

don't show value on LCD

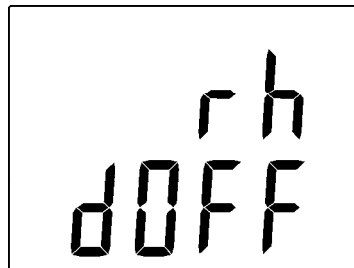

-
-
-

Show computed value at LCD display

This item provides to choice if actual computed value may be displayed at LCD display or not. There is shown the name of computed value on the top LCD line – see “Computed value selection“ below. It is possible to change it after „SET“ key pressing.

show value on LCD

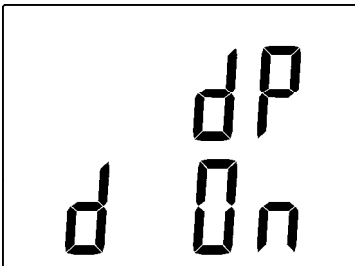

don't show value on LCD

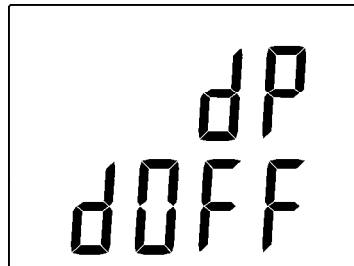

Computed value selection

It shows the actually selected computed value name. It is possible to change it after „SET“ key pressing. There is possible choice one of the following computed values:

dew point temperature

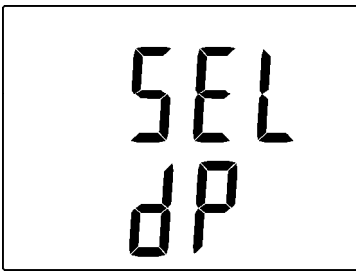

absolute humidity

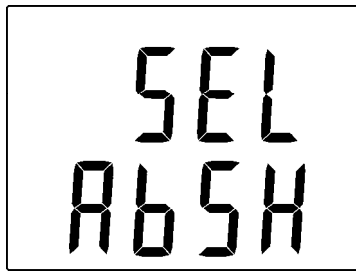

mixing ratio

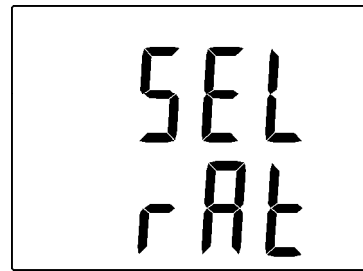

specific humidity

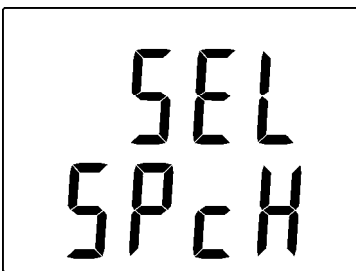

specific enthalpy

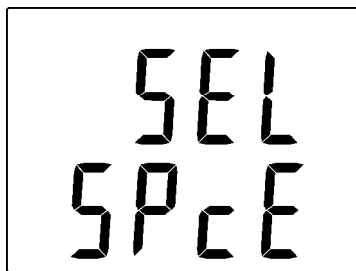

4.4. Restore to „Factory default“ – measurement part

This item provides regulator restoring to factory setting. Press „SET“ key, select „YES“ and confirm it by pressing of „SET“ key. It reset regulator parameters to following values:

Value assigned to relay 1 and relay 2:	none
Password for setting through keys (PASS):	0000
display:	on
temperature unit:	°C
correction for altitude:	0 hPa (absolute pressure)
computed value preset:	dew point temperature
relay response for error:	stay unchanged at previous condition
acoustic alarm:	off

restore to factory default

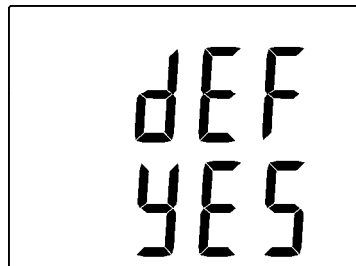
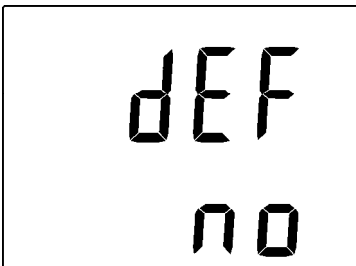

5. Device connection

+U, GND power supply connection

NO1, COM1 normally open contact of relay 1 – when alarm condition is true, contact is closed (LCD shows information about alarm with symbol **ALARM 1**).

NC1, COM1 normally closed contact of relay 1 – when alarm condition is true, contact is opened (LCD shows information about alarm with symbol **ALARM 1**).

NO2, COM2 normally open contact of relay 2 – when alarm condition is true, contact is closed (LCD shows information about alarm with symbol **ALARM 2**).

NC2, COM2 normally closed contact of relay 2 - when alarm condition is true, contact is opened (LCD shows information about alarm with symbol **ALARM 2**).

6.

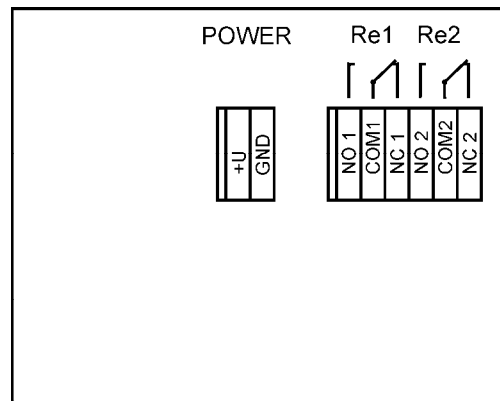

Dimensions

STR-102

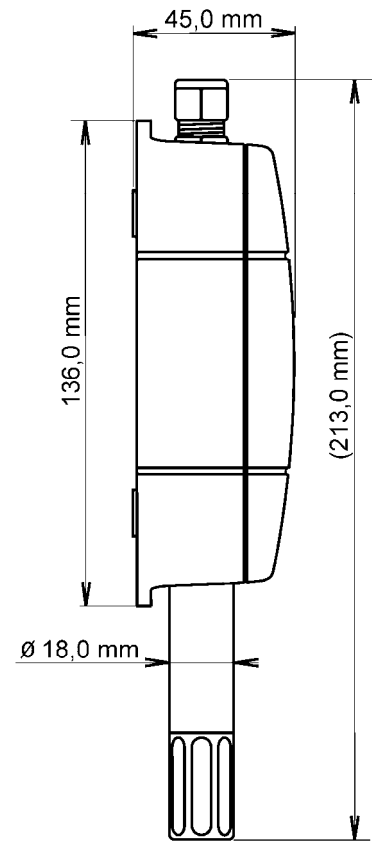
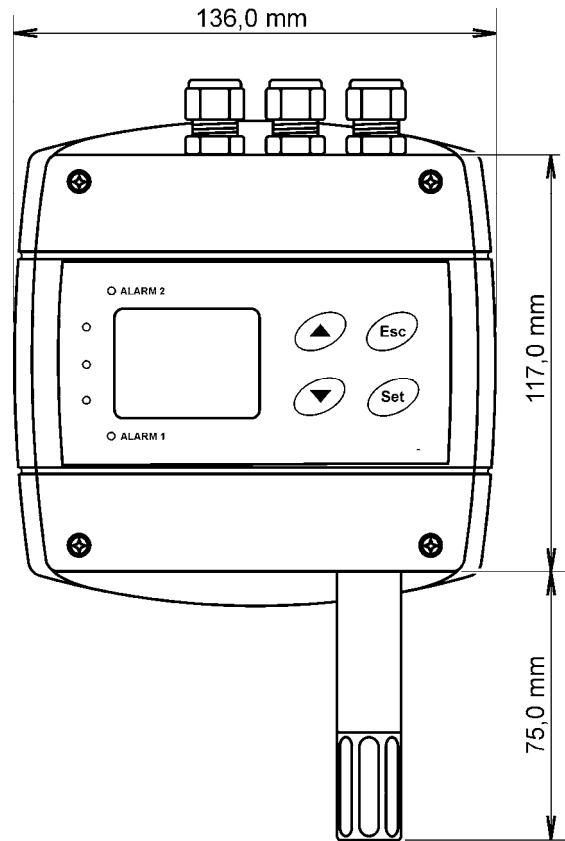

STR-103

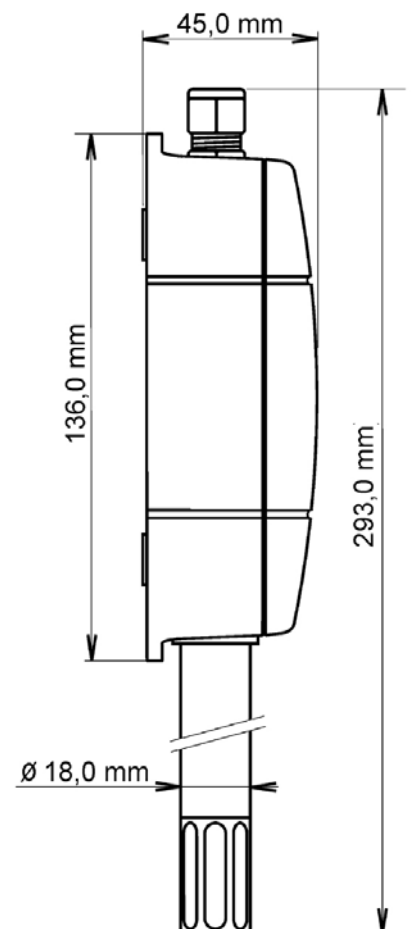
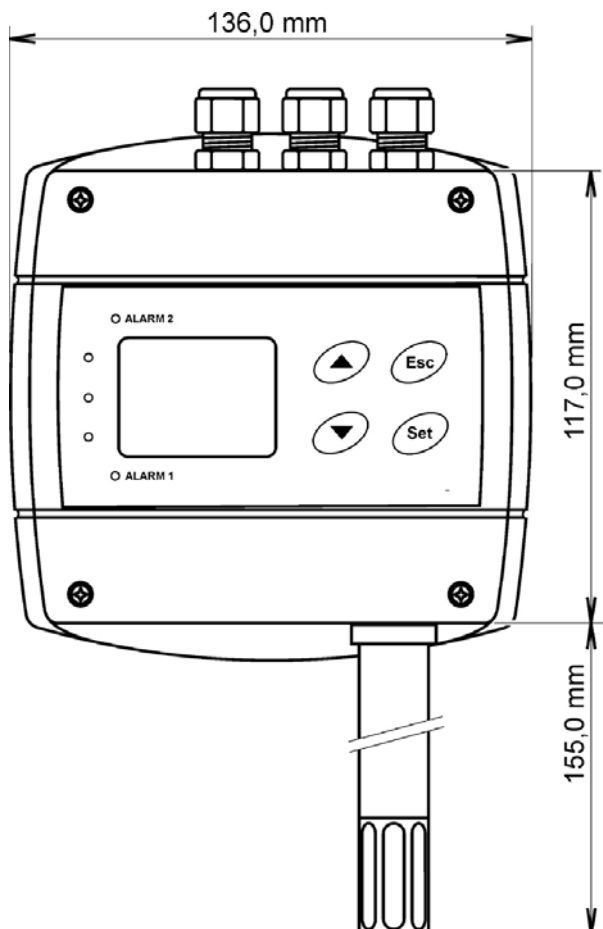

STR-104 (S)

Probe for compressed air measurement

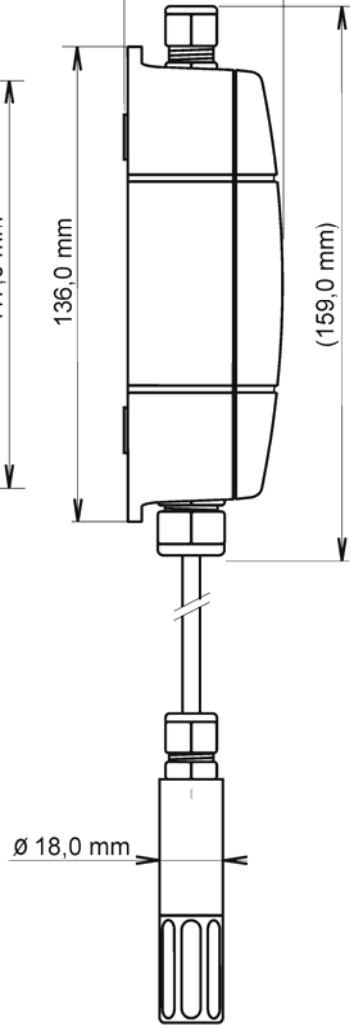
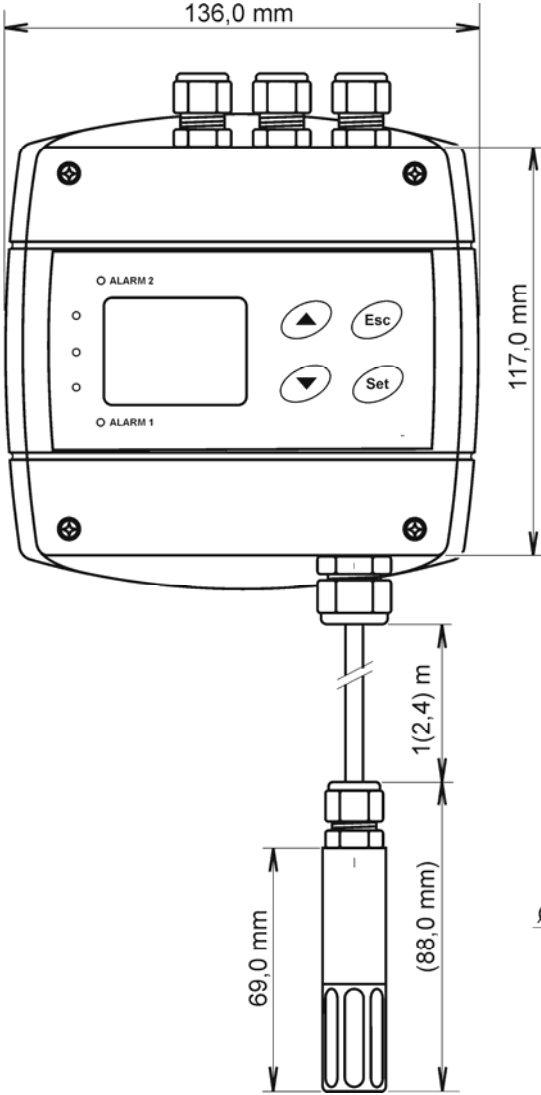
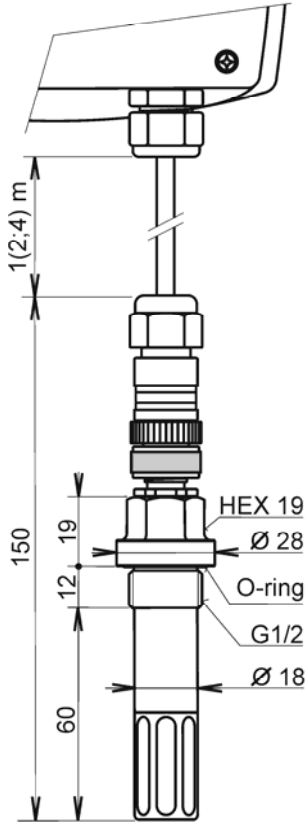

7. Error States of the device

Device continuously checks its state during operation. In case error is found LCD displays corresponding error code:

Error 0

First line of LCD displays „Err0“. Check sum error of stored setting inside device’s memory. This error appears if incorrect writing procedure to device’s memory occurred or if damage of calibration data appeared. At this state device does not measure and calculate values. It is a serious error, contact distributor of the device to fix.

Error 1

Measured or calculated value is over upper limit of allowed full scale range. There is a reading „Err1“ on LCD display. This state appears in case of:

- Measured temperature is higher than approximately 600°C (i.e. high non-measurable resistance of temperature sensor, probably opened circuit).
- Relative humidity is higher than 100%, i.e. damaged humidity sensor, or humidity calculation of humidity is not possible (due to error during temperature measurement).
- Computed value – calculation of the value is not possible (error during measurement of temperature or relative humidity or value is over range).

Error 2

There is a reading „Err2“ on LCD display. Measured or calculated value is below lower limit of allowed full scale range. This state appears in case of:

- Measured temperature is lower than approximately -210°C (i.e. low resistance of temperature sensor, probably short circuit).
- Relative humidity is lower than 0%, i.e. damaged sensor for measurement of relative humidity, or calculation of humidity is not possible (due to error during temperature measurement).
- Computed value – calculation of computed value is not possible (error during measurement of temperature or relative humidity).

Error 3

There is a reading „Err3“ on LCD display upper line. Error of internal A/D converter appeared (converter does not respond, probably damage of A/D converter). Values are NOT measured. It is a serious error, contact distributor of the device.

Error 5, 6

There is problem with assigned value to output relay, there is some wrong setting (mismatch). This error appears if incorrect writing procedure to device’s memory occurred.

Error 9

Inserted password is not valid, there is shown for short time message “Err9” on LCD display. Try to insert password again. If you forgot the password see chapter Change of “Password for setting through keys” (PASS) at page 11.

8. Readings on LCD display

°C, °F - reading next to this symbol is measured temperature or error state of value

%RH - reading next to this symbol is measured relative humidity or error state of value

°C / °F DP - reading next to this symbol is calculated dew point temperature or error state of value

g/m³ - reading next to this symbol is calculated absolute humidity or error state of value

g/kg - reading next to this symbol is calculated specific humidity or mixing ratio (depends on device setting) or error state of value

If specific enthalpy is selected, there is shown only value (number) without corresponding unit

3 - this symbol is on if jumper is closed

9. Technical specification

9.1. Technical parameters

9.1.1. Common parameters

Power voltage: 9 to 30 V DC

Power consumption: approx. 1 W

Measuring interval: 1 s

Display switching interval: 4 s (when more than two values are displayed)

Protection: electronics IP65, sensors are located in cover with IP40 protection

Relay outputs:

Amount: 2

Maximal voltage: 50 V

Maximal current: 2A

Maximal power: 60 VA

Relays contact is not designed for direct control of line voltage!

(output relay contact parameters: max 220Vdc, 125Vac, 2A, 60 W, 62.5 VA)

EMC: EN 61326-1:2006, EN 55011:2007, EN55022:2006 + A1:2007

EN 61326-1:2005, chap.6.2, tab.1

9.1.2. STR-102 - temperature and humidity regulator

Temperature:

Accuracy: $\pm 0,4$ °C ($\pm 0,7$ °F)

Range: -30 to +105 °C (-22 to 221 °F), includes probe cable

Resolution: 0,1 °C (0,2 °F)

-

Relative humidity:

(reading is temperature compensated at entire temperature range)

Accuracy: $\pm 2,5$ %RH from 5 to 95 %RH at 23 °C (73,4 °F)

Range: 0 to 100 %RH

- Resolution: 0,1 %RH

- **Measuring temperature and humidity range is limited in accordance with the graph below!**

Response time (air flow approximately 1 m/s):

temperature: $t_{90} < 7$ min (temperature step 20 °C (36 °F)) with stainless steel mesh sensor cover (ATS-AC12B)

$t_{90} < 9$ min with bronze sensor cover (ATS-AC13 - selectable option)

relative humidity: $t_{90} < 30$ s (humidity step 65 %RH, constant temperature)

9.1.3. STR-104(S) - temperature and humidity regulator**Temperature:**

Accuracy: $\pm 0,4$ °C ($\pm 0,7$ °F)

Range: -30 to +105 °C (-22 to 221 °F), includes probe cable

- Resolution: 0,1 °C (0,2 °F)

Relative humidity:

Accuracy: $\pm 2,5$ %RH from 5 to 95 %RH at 23 °C (73,4 °F)

Range: 0 to 100 %RH

- Resolution: 0,1 %RH

- **Measuring temperature and humidity range is limited in accordance with the graph below!**

Response time with stainless steel mesh sensor cover (ATS-AC12B) and bronze sensor cover (ATS-AC13 - selectable option), air flow approximately 1 m/s:

temperature: $t_{90} < 9$ min (temperature step 20 °C (36 °F))

relative humidity: $t_{90} < 30$ s (humidity step 65 %RH, constant temperature)

9.1.4. STR-103 - temperature and humidity regulator**Temperature:**

Accuracy: $\pm 0,4$ °C ($\pm 0,7$ °F)

Range: -30 to +125 °C (-22 to 257 °F)

Resolution: 0,1 °C (0,2 °F)

Relative humidity:

Accuracy: $\pm 2,5$ %RH from 5 to 95 %RH at 23 °C (73,4 °F)

Range: 0 to 100 %RH

Resolution: 0,1 %RH

- **Measuring temperature and humidity range is limited in accordance with the graph below!**

Response time with stainless steel mesh sensor cover (ATS-AC12B) and bronze sensor cover (ATS-AC13 - selectable option), air flow approximately 1 m/s:

temperature: $t_{90} < 9$ min (temperature step 20 °C (36 °F))

relative humidity: $t_{90} < 30$ s (humidity step 65 %RH, constant temperature)

9.1.5. Relative humidity and temperature restriction

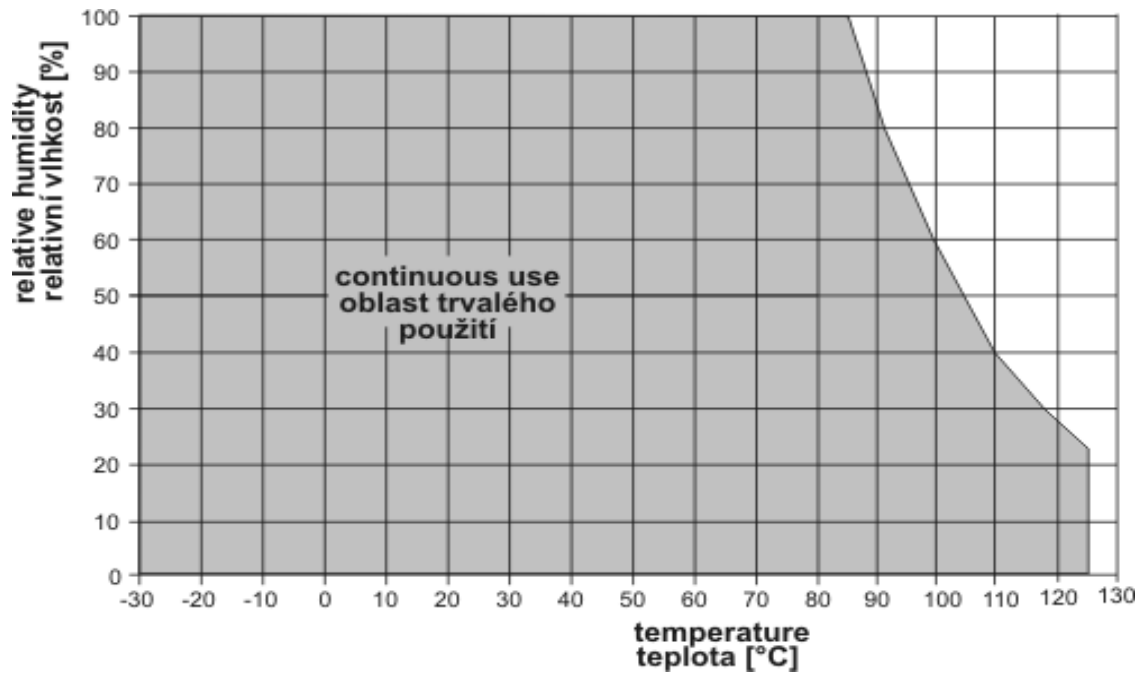

9.1.6. Value computed from measured relative humidity and temperature

Dew point temperature

Range: -60 to +80 °C (-76 to 176 °F)

Accuracy: $\pm 1,5^{\circ}\text{C}$ ($\pm 2,7^{\circ}\text{F}$) at ambient temperature $T < 25^{\circ}\text{C}$ (77°F) and relative humidity $\text{RH} > 30\%$, for more details see graphs below

Note: for accuracy and range of computed dew point temperature for compressed air measurement up to 25 bars (regulator STR-104S) see Appendix B

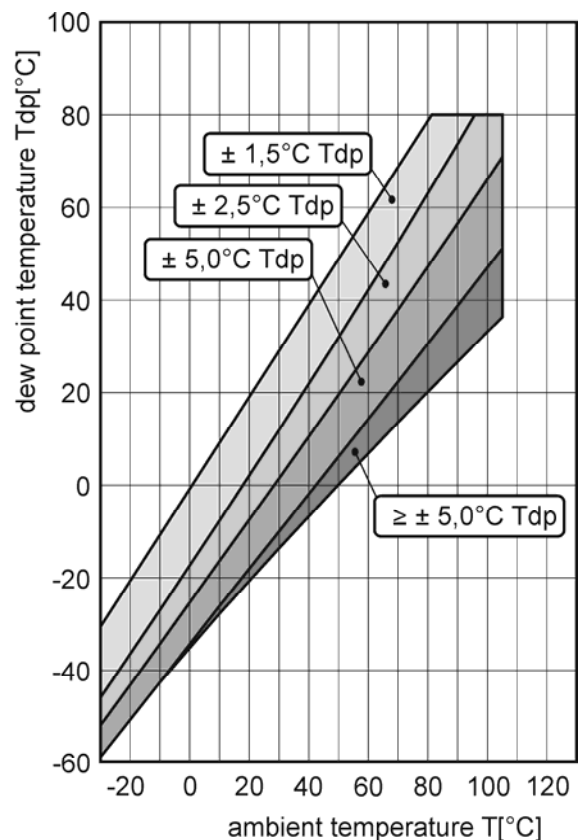
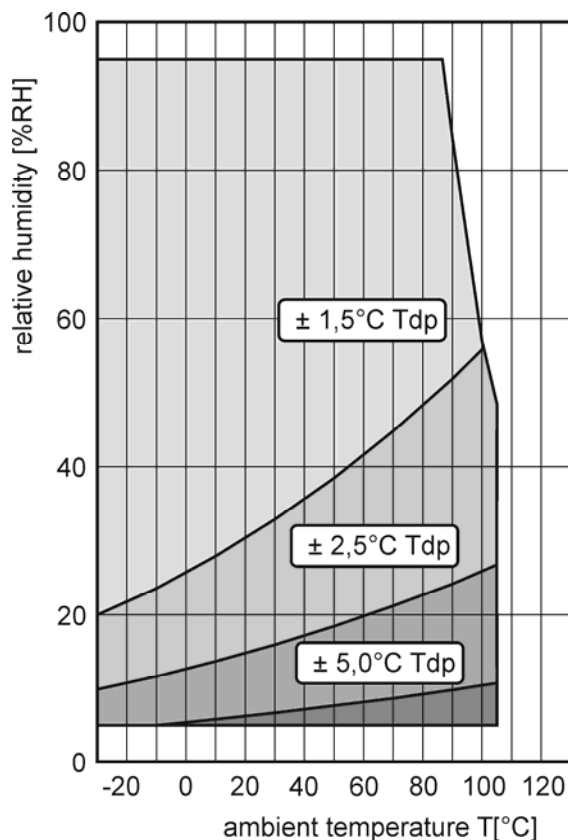

Absolute humidity

Range: 0 to 400 g/m³

Accuracy: ±1,5 g/m³ at ambient temperature T < 25°C (104 °F), for more details see graph below

Note: for accuracy of computed absolute humidity for compressed air measurement up to 25 bars (regulator STR-104S) see Appendix B

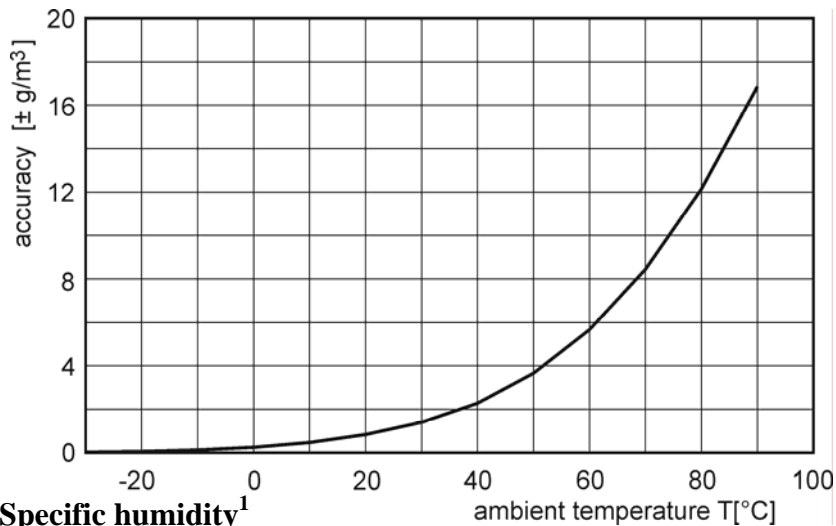

Specific humidity¹

Accuracy: ±2g/kg at ambient temperature T < 35°C (95 °F)

Range: 0 to 550 g/kg

Mixing ratio¹

Accuracy: ±2g/kg at ambient temperature T < 35°C (95 °F)

Range: 0 to 995 g/kg

Specific enthalpy¹

Accuracy: ± 3kJ/kg at ambient temperature T < 25°C (77 °F)

Range: 0 to 995 kJ/kg ²

9.2. Operating conditions

Operating temperature and relative humidity:

electronics : -30 to +80 °C (-22 to 176 °F), 0 to 100 % RH (without condensation)

probe STR-104 (S): -30 to +105 °C (-22 to 221 °F) probe cable included, 0 to 100 %RH

measuring tip with sensors STR-103: -30 to 125°C (-22 to 257 °F), 0 to 100%RH

It is recommended to switch off the LCD display at ambient temperatures above 70°C (158 °F) – around electronics.

Operating pressure range of probe STR-104S: up to 25 bars

Working position:

STR-104 (S) negligible

STR-102, STR-103 with sensor cover downwards

Not allowed manipulations: It is not allowed to operate the device under conditions other than specified in technical parameters. Devices are not designed for locations with chemically

¹ This value depends on the atmospheric pressure. For computing is used constant value stored in device memory. Default value preset by manufacturer is 1013hPa and can be changed by user's software.

² This maximum is reached under conditions about 70°C/100%RH or 80°C/70%RH

aggressive environment. Temperature and humidity sensors must not be exposed to direct contact with water or other liquids. It is not allowed to remove the sensor cover to avoid any mechanical damage of the sensors.

Mechanical connection of probe STR-104S: G1/2 with O-ring

Storing conditions: temperature -30 to +80 °C (-22 to +176 °F), humidity 0 to 100 %RH without condensation

Dimensions: see dimensional drawings

Weight: approximately:

STR-102	350g	
STR-104/1m probe	400g,	STR-104S/1m probe 450g,
STR-104/2m probe	440g,	STR-104S/2m probe 490g,
STR-104/4m probe	520g	STR-104S/4m probe 570g
STR-103	420g	

Material of the case: ABS

Material of the probe STR-104S: duralumin with the black eloxal surface finish

9.3. End of operation

Device itself (after its life) is necessary to liquidate ecologically!

-

9.4. Technical support and service

Technical support and service is provided by Atal B.V.

10. Appendix A

Connection of external power relay

Coil data chart of external power relay:

nominal voltage : max. 50V
 nominal power: max. 60VA
 current: max. 2A

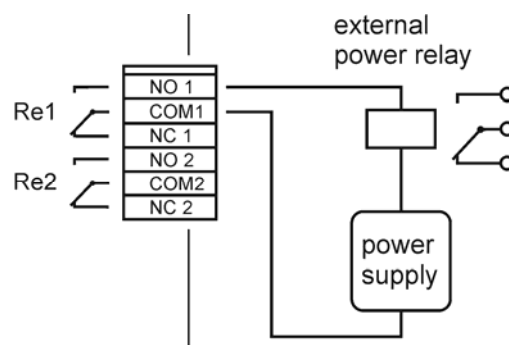

11. Appendix B

Accuracy of computed absolute humidity for compressed air measurement up to 25 bars.

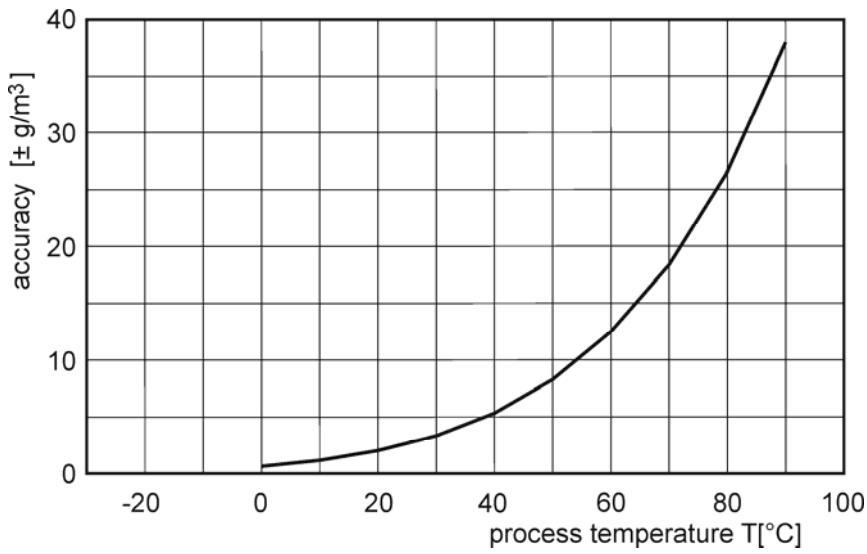

Accuracy and range of computed dew point temperature for compressed air measurement up to 25 bars.

